

IF IN DOUBT, ASK

DO NOT SCALE

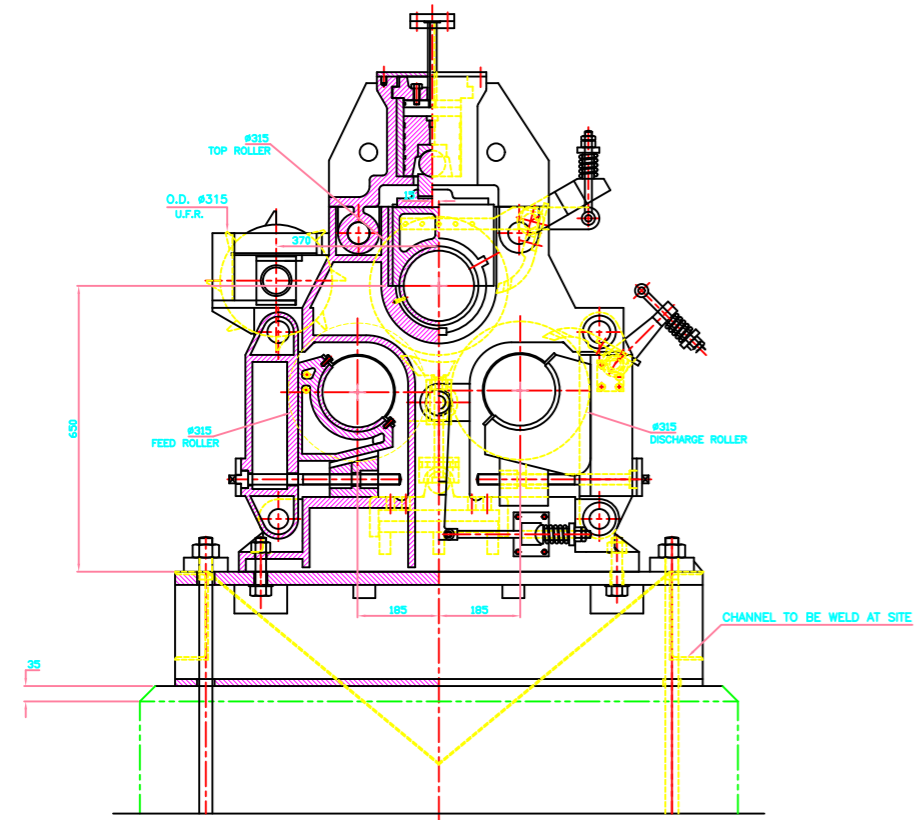

SECTION-AA

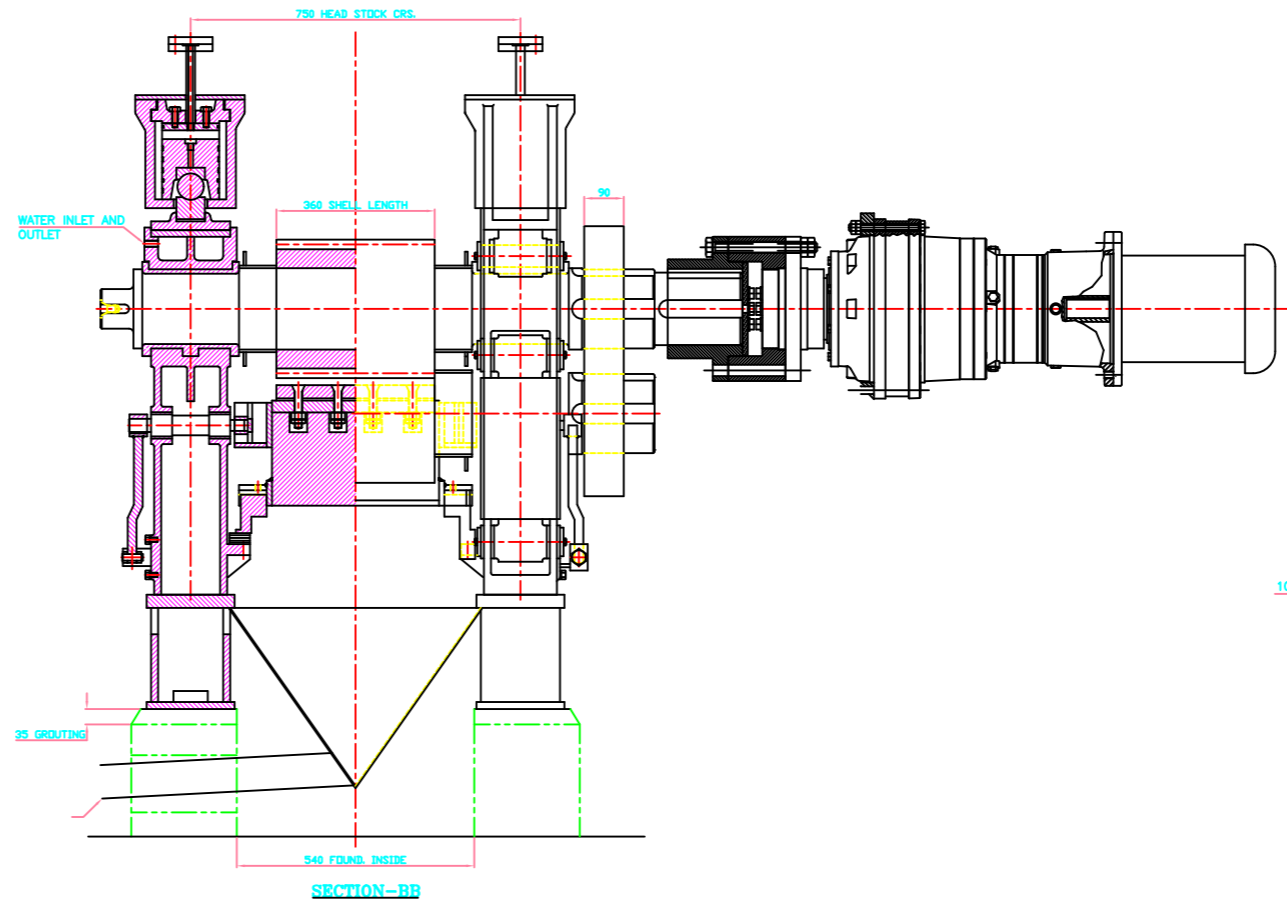
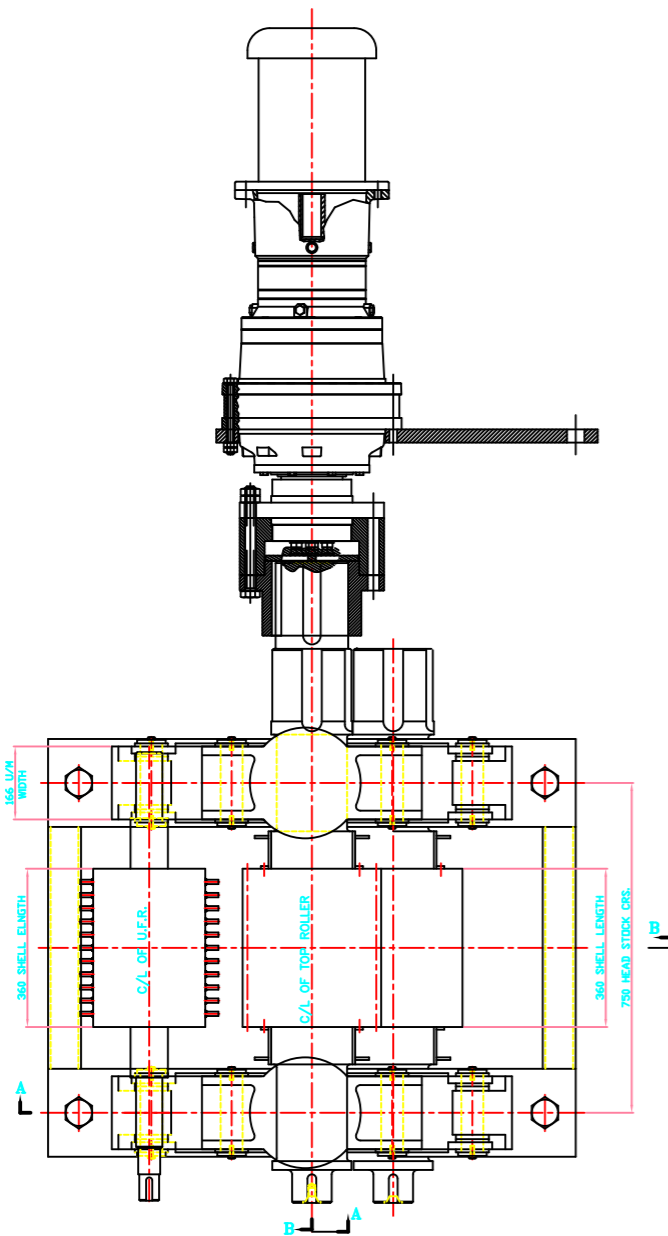

SECTION-BB

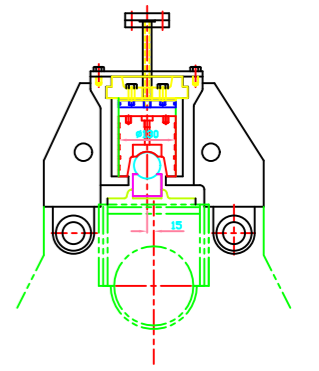

10TEETH, 30M, CROWN PINION

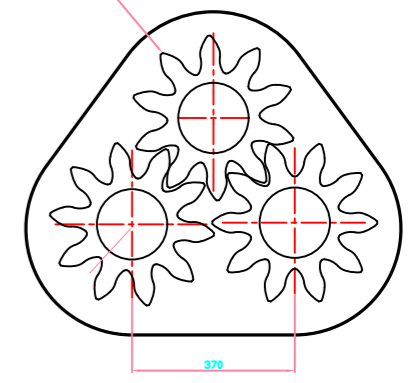

- 1) ALL BEARING WITH LINER TO BE BLUE MATCH WITH RESPECTIVE ROLLER.
- 2) BASE FRAME MUST BE GROUDED UP TO 70% AFTER FINAL TIGHTENING AND GUTTER WELDING.
- 3) DIGNOAL MUST BE MAINTAIN WITHIN 0.02.

REV. NO.				DESCRIPTION				DRN. BY				CHD. BY				DATE			
CLIENT: PRECISION ENGINEER NAME: RSD DATE: TITLE: SCALE: ASSEMBLY OF #12"x14" MILL AMEY ENGINEERS 5-05 BARKERWAY BUSINESS COMPLEX, FORTLA, FLORIDA 32209-10 904-880-0000 - 41000, 904-880-1000 FAX: 904-880-0000, 904-880-1000																			
ORG. NO. AE/A1/620																			

THE ABOVE AND THEREIN IS THE PROPERTY OF PRECISION ENGINEER AND SHALL BE KEPT IN CONFIDENCE AND NOT TO BE REPRODUCED OR COPIED IN ANY MANNER WITHOUT THE PERMISSION OF PRECISION ENGINEER.